

***RF Calibration Techniques
using the
AARTS System***

AN #20060405-01

Rev B – April 9, 2009

Accel-RF Corporation specializes in the design, development, manufacture, and sales of accelerated life-test/burn-in test systems for RF and Microwave semiconductor devices. This white paper describes technical information related to the AARTS Hardware. For more information contact:

***Accel RF Corporation
10401 Roselle St. Suite 400
San Diego, CA 92121
(858) 332-0707***

Table Of Contents

1	Overview.....	1
1.1	LifeTest Calibration Routines	3
1.2	Accounting for Fixture Losses	5
1.3	Evaluating Calibration Performance.....	8
2	Summary	10

1 Overview

This document discusses issues related to calibrating RF measurements in the Accel-RF AARTS system. The AARTS life test system may be used to monitor RF- and DC-parameter degradation. It is designed to facilitate accurate measurements by using calibration techniques that cause internal measurements to match those made by an external piece of equipment. In the case of DC voltages, DC currents, and temperature measurements, an external reference standard comprises a metrology-grade instrument which is not part of the system. However, for RF power measurements the “reference” standard is the built-in Agilent RF power meter, which typically includes two power heads.

The functional block diagram of a typical RF system is presented in Figure 1. The primary RF stimulus is generated by the broadband RF Unit (RFU), with an optional Solid State Power Amplifier (SSPA) available to generate higher RF drive levels over a narrower band of frequencies. Figure 2 shows the RFU and SSPA connections in greater detail, including the calibration paths.

Figure 1: AARTS System Block Diagram

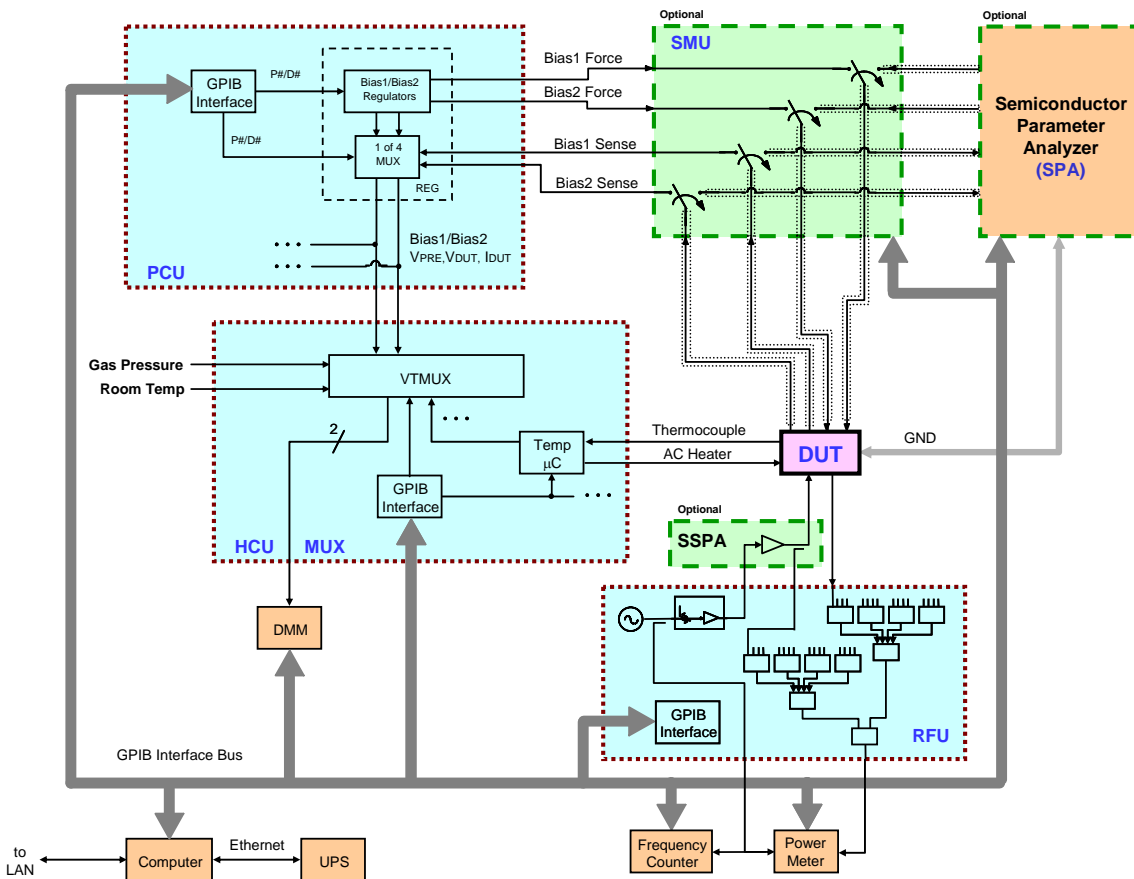
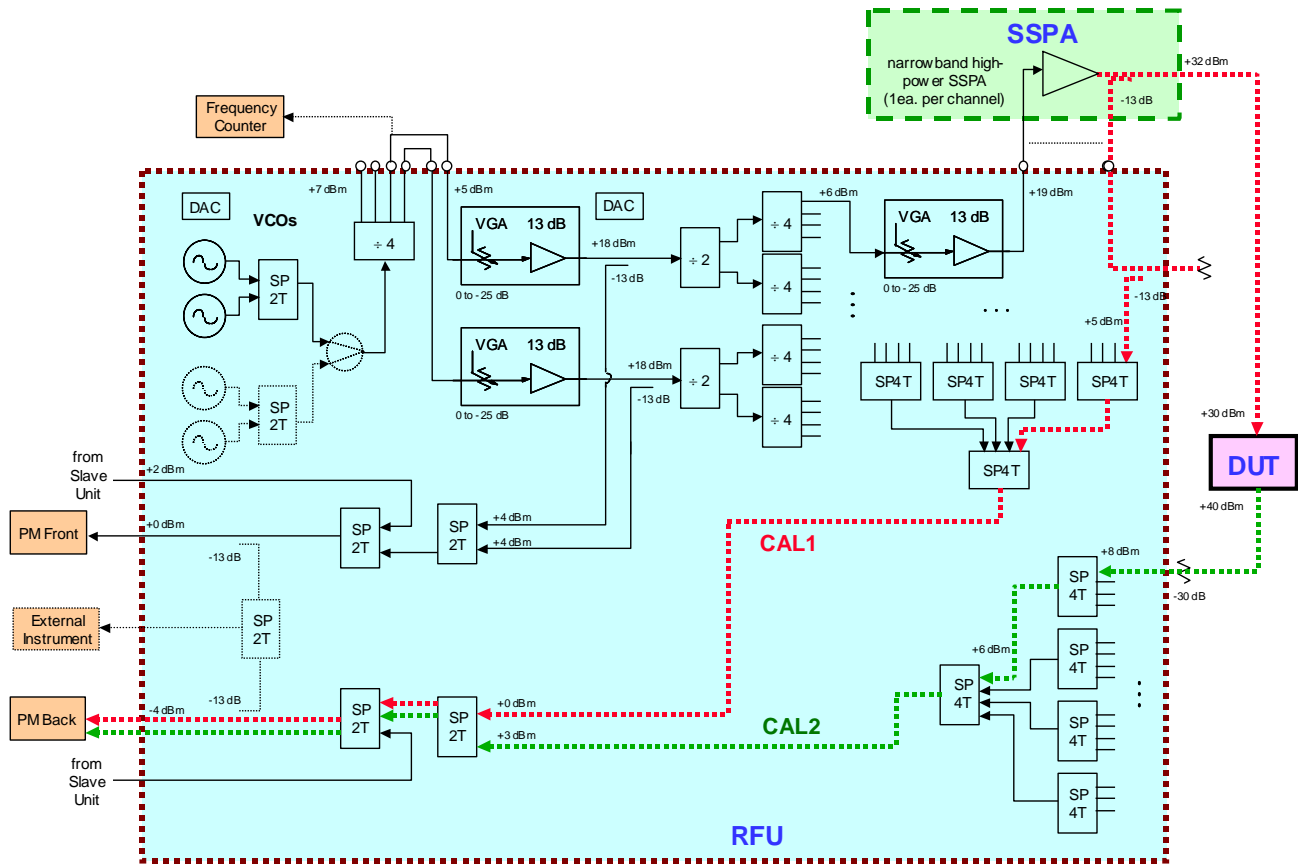

Figure 2: RFU Block Diagram



The Cal1 and Cal2 calibration factors support a very basic magnitude-only calibration for RF measurements. The technique for calibrating the Cal1 path is to place one of the power meter heads at the DUT input, selecting the channel of interest to route a sample of the output signal through the RF switch matrix assembly to a second power meter head permanently mounted on the back of the RFU, and determining an offset comprised of the difference between the two readings. Future measurements may be referenced to the DUT input by adding the Cal1 factor to the back-meter reading.

In a similar manner, a through connection is placed between the DUT input and output for calibrating the Cal2 factors. Both Cal1 and Cal2 factors are frequency dependent and the LifeTest software provides a method for calibrating over a user-defined frequency range. Although the RF switch matrix components comprise FET switching devices, the loss through the switch is assumed to be independent of RF power level (note: the coupling factors and RF power-pad values are designed to scale the RF signals to levels well below the rated saturation points of the RF switches). Hence, calibration factors at one power level may be used for all other levels. Typically, the maximum power level is chosen as that minimizes calibration time. Nevertheless, for maximum accuracy the operator may choose to calibrate at the power level of interest.

1.1 LifeTest Calibration Routines

The AARTS LifeTest software provides several user interfaces for calibrating the RF path losses. The main RF calibration control, presented in Figure 3, is used to manage the calibration process. By checking the “Use Defaults” check box in the “Default Values” window at the top, a user-specified frequency range and number of points may be defined. The Cal1 and Cal2 channel lists may be used to tag any number of channels for calibration. Right-click over a selected channel and click on “Calibrate” to launch the Cal1 and Cal2 calibration procedures.

Figure 3: Main RF Calibration Form

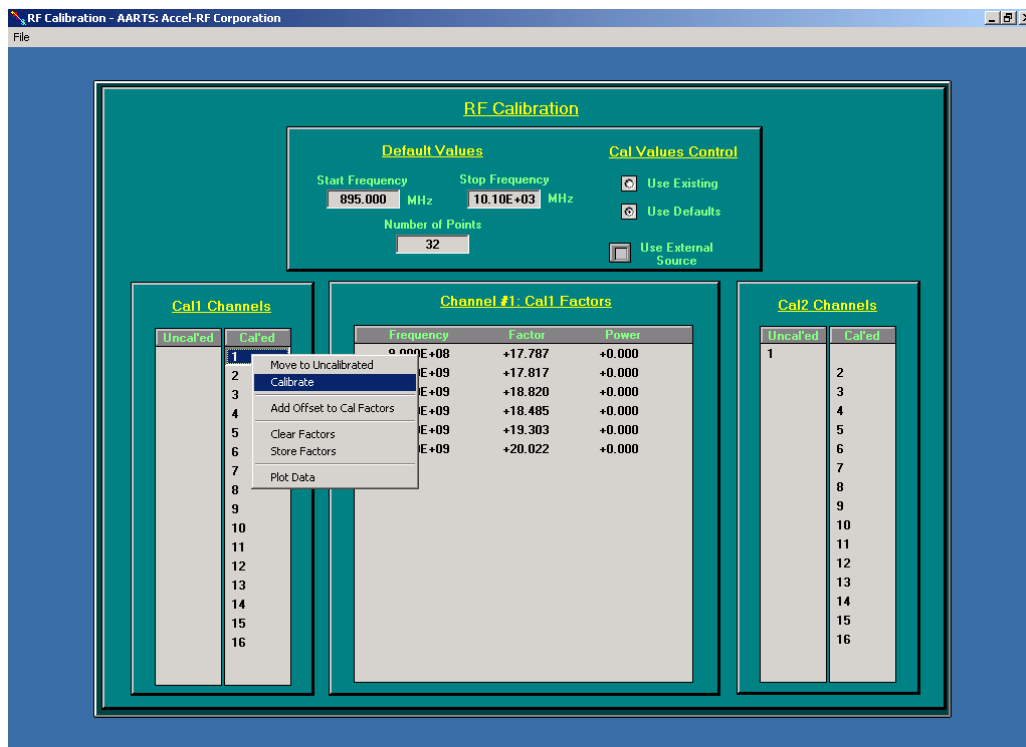

The Cal1 and Cal2 Forms, shown in Figure 4 and Figure 5, provide a way to perform single-step events requiring user interaction (refer to the AARTS software manual for detailed instructions on using the Calibration routines). For instance, in the Cal1 process, the user must attach the external power-meter head to the DUT input. Note that the SSPA could deliver enough power to the DUT input to damage the sensor head; hence, a power-pad is recommended as stated in the Cal1 instructions. The pad loss may be defined as a constant by typing in the value to “Power Pad Value” text box at the appropriate time, or a standard S-Parameter file (similar to the s2p file format shown in Table 1) could be generated on a vector network analyzer and used by checking the “Use Pad Cal File” checkbox. An additional loss factor may be entered after the calibration process to account for connector or fixture losses. That loss applies to both the Cal Factor and the input power level measurements. As with the pad value, an s2p cal file could be used as well.

The Cal2 process follows a similar procedure; however, the additional loss item only applies to the Cal2 Factor, not to its associated input power measurements.

Table 1: Pad Cal File Format

```

!* ANA DATA ACQUISITION SYSTEM VERSION 5.00.
!*
!* PROCESS LINE          DATE      2/4/2008, 3:09 PM
!*
!* Port 1 resistance = 0.00 Ohm, Port 2 resistance = 0.00 Ohm.
!*
!* Freq[GHz]  dB(S11)  Phase(S11)  dB(S21)  Phase(S21)  dB(S12)  Phase(S12)  dB(S22)  Phase(S22)
# GHZ S DB R 50.0000
6.0000      -23.7987    162.4160     -1.2594     94.0440     -1.3125     94.2385     -29.4758    100.3898
6.2500      -20.9236    131.6428     -1.2404     37.8494     -1.2894     38.0821     -27.9721     90.4159
6.5000      -19.8807     96.1495     -1.2321    -18.2807     -1.2798    -18.0880    -27.1160     80.1227
6.7500      -20.8257     58.5531     -1.1969    -74.4327     -1.2513    -74.2354    -26.8643     68.8136
7.0000      -24.5758     18.0551     -1.1721   -130.7866     -1.2182   -130.5724    -27.0144     58.7874
7.2500      -34.5266    -45.3601     -1.1594    172.9022     -1.2022    173.0861    -27.5227     48.1893
7.5000      -31.9864    165.6930     -1.1335    116.5241     -1.1816    116.6928    -28.5947     38.1534
7.7500      -27.3235    118.7631     -1.1211     60.0964     -1.1669     60.2667    -30.2957     30.7470
8.0000      -27.8071     88.4319     -1.0964     3.7147     -1.1463     3.8595    -33.1011     27.3304
    
```

Figure 4: RF Cal1 Calibration Form

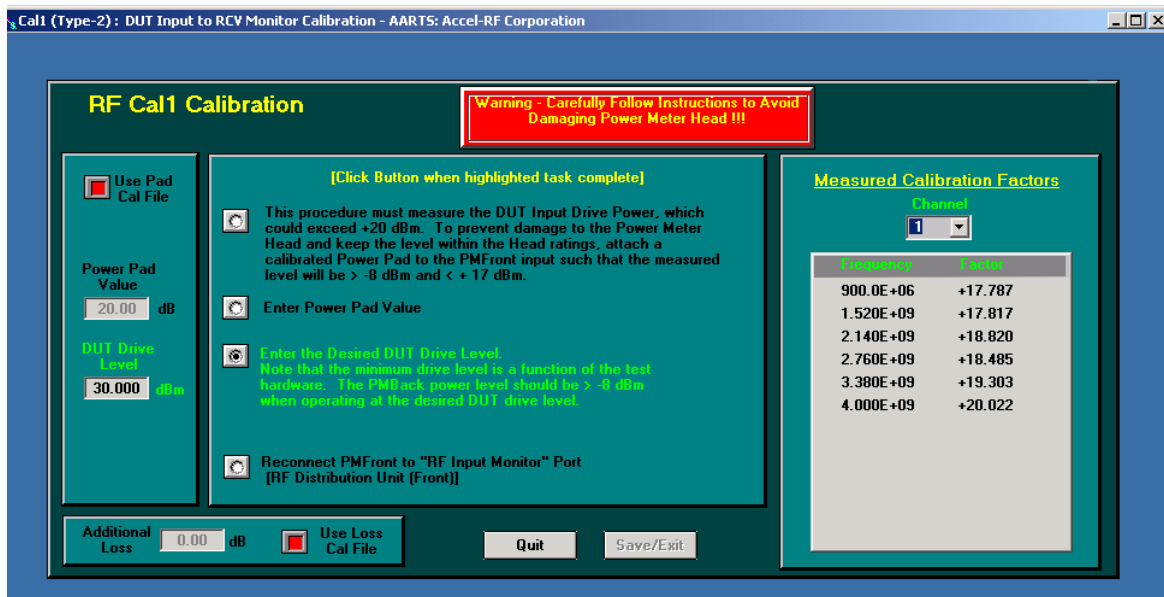

Figure 5: RF Cal2 Calibration Form

RF Cal2 Calibration

[Click Button when highlighted task complete]

This routine measures the relative power levels between the DUT output and the RCV Monitor port. Care must be exercised to avoid operating the power meter heads outside their optimal operating range. Refer to the hardware block diagram of the RF distribution to determine the appropriate levels.

Verify PMBack is Connected to "RCV Monitor" Port [RF Distribution Unit (Back)]

Enter the Desired DUT Drive Level
Note that the minimum drive level is a function of the test hardware. The PMBack power level should be ≥ -8 dBm when operating at the specified DUT drive level connected through a shunting THRU cable.

DUT Drive Level: 30.00 dBm

Additional Offset: 0.00 dB Use Offset Cal File

Quit Save/Exit

Measured Calibration Factors

Channel: 1

Frequency	Factor
900.0E+06	+33.004
1.520E+09	+33.428
2.140E+09	+33.709
2.760E+09	+34.212
3.380E+09	+34.970
4.000E+09	+35.222

1.2 Accounting for Fixture Losses

The calibration procedure discussed in Section 1.1 yields known power levels at the fixture input/output. However, the power delivered to the device will be lower due to circuit losses in the transition from the fixture outside connectors to the device interface. To accurately determine total power loss in the device, required to extract channel temperature, the correct RF power levels into and out of the part are needed - particularly output power. Input power is generally at least 10 dB lower than output power (based on device gain); hence, its contribution to overall power dissipation is of less importance. Since device degradation is of primary importance, absolute gain accuracy is also not critical. Nevertheless, considering total 50- Ω fixture loss can exceed 3 dB (dependent on frequency), it is useful to define a procedure for translating the calibration point to the device input and output.

Figure 6 presents a picture of a standard RF fixture. Note that the device is mounted roughly in the middle of the fixture, on a thermally isolated - yet heated - block. The matching structures are ideally located on the cooler outer area of the fixture as shown. This keeps any components, such as resistors or capacitors from being derated by temperature and thus possibly inducing problems. Further, device degradation will be affected by changes in the matching elements themselves. Like the devices under test, substrate characteristics such as line oxidation, dielectric constant, loss tangent, etc. can experience aging effects. Changes in those parameters affect the load impedances delivered to the device. These effects are aggravated by temperature. Ultimately, the goal is to test device degradation, not the effects of matching circuit changes caused by external component variations; hence, it is recommended that these elements be located on the outer fixture area.

The disadvantage in placing the matching structures far away from the device is that it greatly complicates the ability to achieve broadband performance. Further, techniques to assure unconditional stability over a broad bandwidth often require a brute force approach (i.e. series/shunt resistance), which yields additional loss in overall circuit gain. Nevertheless, there are techniques available to achieve reasonable device performance for life testing purposes.

Figure 6: RF Fixture

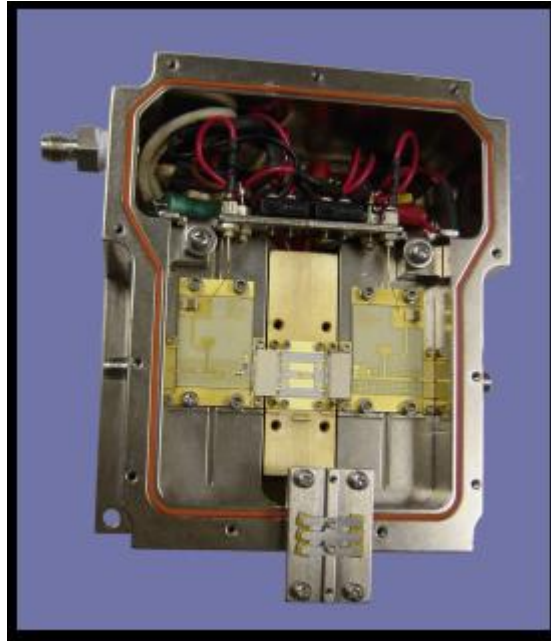

What is the best way to account for losses in the RF fixture to maximize accuracy of device power levels? The pertinent RF components associated with the fixture and RF calibration are illustrated in Figure 7. The fixture coaxial wall-feedthroughs connect to the system via flexible cables mounted on the oven floor. Following the procedures documented in the AARTS software manual, the Cal1 and Cal2 calibration factors yield measurements corrected to the point of the input/output connectors, denoted by blue lines in the diagram.

Lets review how loss affects the calibration factors, specifically Cal2. Note that the Cal2 procedure requires use of a through cable to bridge the gap (roughly 3 inches long) over the fixture. Hence, the initial calibration yields a reference point for the output plane coincident with the input connector. There are two techniques available to adjust the Cal2 factors to rotate its reference to the output connector.

First, the Cal2 routine offers an option to account for additional losses in the through cable, which allows the reference plane to be rotated to the “output” connector. If an s2p file is used for removing those losses, the program automatically adjusts the factors correctly. However, if the user enters an offset amount directly, the proper sign must be applied. The Cal2 factor represents the cable loss between the back power-meter head and the calibration point. A typical value may be 40dB. By removing the through cable, that loss factor decreases. Hence, the loss must be “subtracted” from the values to rotate the reference point from the input connector plane to the output connector plane. For example, if the loss of the cable is 1dB, the new Cal2 factor should be 39dB after adjustment.

A second approach to account for cable loss is available in the main RF Calibration Form (Figure 3). Multi-select and Right-Click over a channel(s) of interest and select “Add Offset to Cal Factor”. A fixed offset may be added to the values. Fortunately, calibration is generally over a fairly narrow frequency bandwidth as compared to the cable response, and hence, its loss (L_c) may be considered constant at all frequencies. Again, the sign must be correct to yield proper results. So, to remove the effect of cable loss on Cal2 adjustment, “subtract” the loss from the factors (e.g. 40dB -> 39dB). Note that no change will occur to Cal2 “input” power readings as that is not a function of the Cal2 factor, but only Cal1.

Now consider the losses in the fixture itself between the connector planes and device. To adjust the calibration factors to account for these fixture losses, the input and output loss amounts, L_i and L_o respectively, must be determined. One approach to determining these values is to insert a 50- Ω through in place of the device, measuring the overall fixture loss, and splitting that amount in half for each side. For those systems testing 50- Ω devices, such as a matched MMIC, this approach provides a very good approximation. However, when testing a non-50- Ω device, such as a single transistor, often input and output matching circuits must be employed to properly match the device. This, by definition, changes a number of factors. For instance, the amount of loss through the fixture (with a 50- Ω through) would not necessarily equal the amount of total input/output loss (due to impedance mismatch reflection issues). Further, if stabilization components, such as series/shunt resistors, are used to guarantee unconditional stability a disproportionate amount of loss will exist on one side (typically the input side). Hence, dividing overall loss by two no longer makes sense.

Figure 7: Fixture Losses

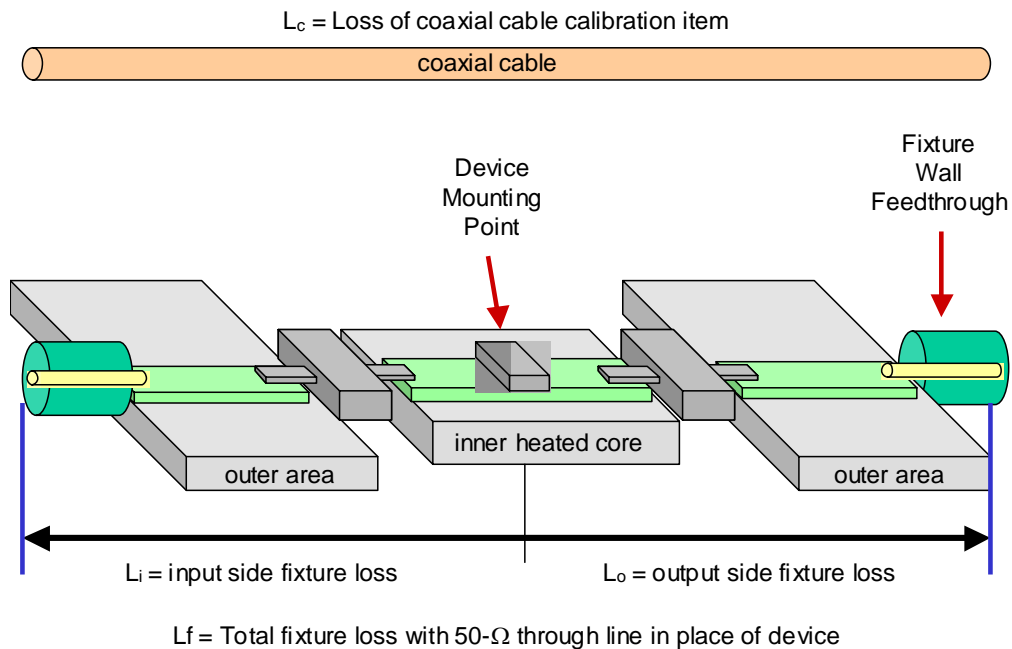

Several methods could be used to account for this effect. First, a CAE model could be generated that predicts the proper amount of loss. The model could be validated by predicting the overall fixture loss with a 50- Ω through, then removing the through from the model to ascertain the input and output loss amounts. A second approach is to measure the loss through the fixture by replacing the "matching circuits" with 50- Ω throughs. This gives a reference against which to compare the same measurements made with the actual circuits. Then, dependent upon the nature of the input- and output- matching structure make an educated estimate of the loss ratios. Finally, fixture performance could be compared against wafer-level test results and losses estimated as the difference, again attributing a slight bit more to the input vs. output if lossy elements exist. Practically, if a circuit has lossy stabilization elements in the input and reasonably low-loss matching elements on the output, a 2/3 vs. 1/3 split of the overall measured loss through the fixture provides a reasonable estimate. So, considering an overall loss through the fixture of 3 dB, L_i = 1 dB and L_o = 2 dB.

Once the loss amounts are determined, the next question is how to incorporate them into the calibration routines. Again, there are two options. First, the additional loss amounts could be entered during the Cal1 or Cal2 process. For Cal1, the additional loss directly decreases the calibration factor, and lowers the input power-level readings accordingly. This yields a known input power roughly at the center of the fixture. A second option is available in the RF Calibration Form. Multi-select and Right-Click over a channel(s) of interest and select “Add Offset to Cal Factor”. A fixed offset may now be added to the values. To rotate the reference plane into the device, “subtract” the loss from the existing factors. Again, the input power level should reflect a lower level after the process as the additional fixture loss decreases available power at the device input. As described earlier, the additional loss required to compensate the output side (Cal2) is “added” to the Cal2 factor in order to rotate the plane from the output connector to the output of the device.

Note that the LifeTest program has no memory of what was added or subtracted to the Cal Factors, so it is important to keep track of these manipulations in order to yield accurate results. Often, it is more convenient to perform all calibrations (i.e. Cal1 and Cal2) without applying any offsets until everything is complete. Then, using the RF Calibration Form apply additional offsets as needed. This technique yields estimated input and output power levels at the device interface.

1.3 Evaluating Calibration Performance

Once the calibration procedures are complete, it is useful to evaluate the suitability of the factors for use in the life test measurements. The Cal1 and Cal2 factors are added to the readings of the embedded power meter head located at the back of the test set, a.k.a. PM-back head. The calibration factors are a function of frequency and a suitable number of points should be chosen to avoid discontinuity effects in the frequency response. It is recommended that the set of calibration points include the target life test operational frequency. The RF Calibration Form shows the calibration factors, and associated measured input power levels, in tabular format. Plots of the data may be generated, as illustrated in Figure 8.

A couple of key points exist related to the calibration data set. First, a finite number of frequency points are measured. In the AARTS system operation, immediately prior to any power-level measurement, the frequency is measured and sent to the power meter for inclusion in its calculations. The Cal1 and Cal2 factors also incorporate the frequency value by interpolating or extrapolating the correct factor from the nearest frequency points.

In reality, there are no strong nonlinearities or discontinuities in the RF subsystem. Hence, the curves should exhibit a relatively smooth change over frequency, as shown in Figure 8. Note that, in this example, the frequency resolution is 100 MHz. A larger number of points could have been chosen at the expense of time required to perform the calibration. A tradeoff exists between the number of points and the resultant resolution accuracy. The plots shown here provide a reasonable error of cal factor change between points. However, had the increment been 300 MHz, a 0.3 dB error could have occurred at certain frequencies.

The input-power performance is dependent on the system specifications, but should also be relatively flat over frequency, and should achieve the rated power at the DUT fixture input connector reference plane. The amount of loss between the connector plane and device is very dependent on the input matching circuit requirements. A low-loss 50- Ω transmission line might have as low as 1 dB, base on frequency, but when matching structures and especially stabilization components are included that value could increase to 2 or 3 dB.

Figure 8: Calibration Plots

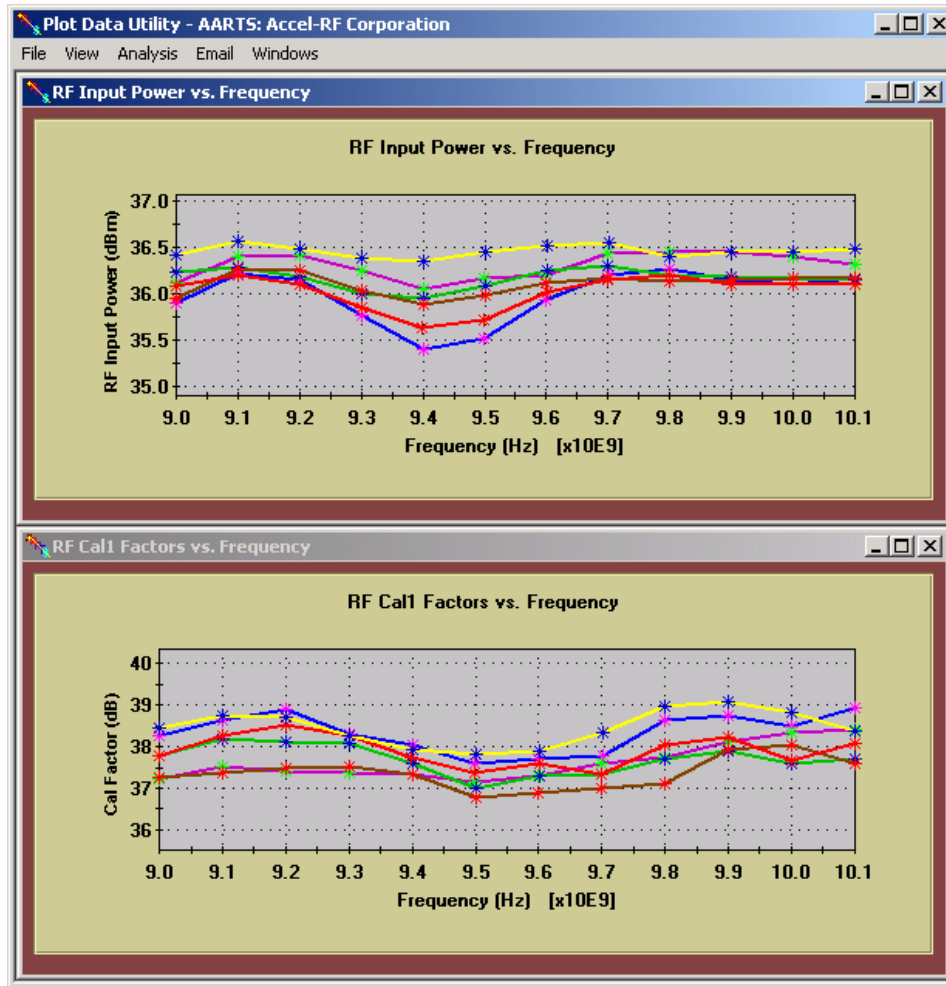

Another factor to be aware of is the effect of reflection mismatch at the DUT input and output ports. Depending on the frequency bandwidth and output power, the SSPA output topology comprises either an isolator or a balanced output configuration. A sample of that output drives a directional coupler. The directivity of the coupler is affected by the load impedance. A very poor DUT input impedance could cause reflection effects on the order of 1-dB or more. An important point to note is that Cal1 factor errors are not as important as Cal2 factor errors. Because the device typically has over 10-dB gain, the errors induced by Cal1 errors are of second-order importance with regard to total power-dissipation calculations. Further, since the life test paradigm is specifically looking for relative changes, as long as the reflection mismatches are somewhat constant, the resultant Cal1 error is not critical.

In contrast, errors in Cal2 would be quite important as that directly affects the determination of channel temperature. Fortunately, the output 50- Ω transmission line is loaded in a fairly large (typically 30-dB) pad at the RFU input. This means the DUT fixture output is presented a very stable and fixed 50- Ω load. Hence, all power launched into the output cabling is by definition delivered to the back PM head, with a loss amount equal to the Cal2 factor. Whatever energy is not launched into the output lines as an RF signal is dissipated in the device.

2 Summary

The techniques described in this document provide a quick and relatively easy approach for maximizing RF measurement accuracy in the AARTS system. This is important for several reasons, but primarily for determining channel temperature through thermal-resistance calculations. Errors in input or output RF power directly reflect as error in total power-dissipation calculations, which in turn create errors in channel temperature, ultimately affecting life test results. Evidently, these errors also impact other factors of interest, such as gain, PAE, and absolute level measurements. Fortunately, most life test paradigms are looking for relative changes as opposed to absolute values. Nevertheless, the more accurate the measurement the more confident the results may be considered.

Several methods to account for fixture losses were discussed. The most practical approach is to measure a fixture with a 50- Ω through in place of the device and splitting the overall loss into amounts commensurate with the input/output matching circuit configurations (typically, a 2/3 vs. 1/3 split is a reasonable approximation if stabilization components and matching impedance structures are employed; or an equal split if 50- Ω structures are used). The Cal1 and Cal2 calibration routines may be performed accounting only for the through coaxial-cable loss. Once both calibration procedures are complete, the appropriate additional input and output loss amounts may be applied to the final calibration factors to yield corrected measurements as referenced to the device input and output ports.